

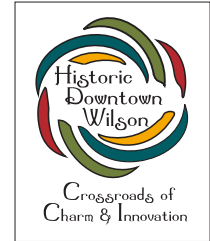

PAINT-A-HYDRANT GUIDELINES/AGREEMENT



BEAUTIFY A HYDRANT
CREATE WHIMSICAL DOWNTOWN ART
SUPPORT FALLEN FIREFIGHTERS ASSOCIATION

Hydrant surface will be prepped by the City of Wilson Hydrant Crew.
Hydrant sponsors will provide their own paint and brushes.
Dropclothes and painter's tape will be provided.

Hydrants will be painted on Saturday, May 20, 2017 at 10 am.
Rain date: June 3, 2017.

SPONSOR / ARTIST REQUIREMENTS

- 1) Hydrants may be beautified using ONLY oil-based enamel paint for metal.
- 2) The property around the hydrant should be kept clean and neat when working on the hydrant. A provided drop cloth must be taped around the bottom of the hydrant covering the sidewalk, ground or any area adjoining the hydrant.
- 3) Paint cannot prevent the functional use of the hydrant. The three openings and the top turning knob must all function. Hydrant threads may not be painted. Paint cannot seep into it to prevent operation.
- 4) Painting may not reduce the hydrant's visibility.
 - * Paint may not be all black, all white, dark camouflage green, or use patterns and/or designs that reduce the hydrant's visibility.
 - * Paint colors may not be the same color as the vegetation or items surrounding the hydrant
 - * Black paint may not cover more than 20% of the overall hydrant
 - * Red paint may not cover more than 50% of the overall hydrant.
- 5) Use bright, vibrant colors
- 6) No attached or added objects may be used. Paint only.
- 7) Design must be appropriate for public places
 - * Paintings/art *cannot* endorse an individual or business.
 - * No offensive, derogatory or obscene graphics.
 - * No gang tags
- 8) No logos, copyrighted or trademarked graphics.
- 9) No copy is allowed anywhere on the hydrant except a 3"x3" area for the artist's signature
- 10) Sponsor may partner with an artist, art class, art school, etc. to design and execute the art. Please contact Susan Kellum at skellum@wilson-nc.org for suggested resources if you need assistance.

AGREEMENT/HOLD HARMLESS:

By signing below and participating in the Paint-A-Hydrant Program, you agree that you have the permission and authority to act as agent for the Sponsor. Additionally, you acknowledge that the City of Wilson, Wilson Downtown Development Corporation, and its affiliates are not responsible in any way for any injury or property damage directly or indirectly associated with this program and/or event.

The design is approved for a 3-year period. During that time, sponsor is available for upkeep of design. If the hydrant is vandalized, sponsor has 30 days to fix and maintain the original, approved design. If hydrant is vandalized with offensive, derogatory or obscene graphics, the City of Wilson hydrant crew reserves the right to paint over/remove the obscenity until the sponsor renews the approved design.

By signing this waiver, the hydrant sponsor is agreeing to all rules, guidelines and criteria associated with Paint-A-Hydrant and is responsible for communicating this information to those executing the design, and supervising the work on your adopted hydrant.

HYDRANT SPONSOR AGENT:

Print Name _____ Representing; _____ Date: _____

Signature _____

PAINT-A-HYDRANT Application



To sponsor, design, and paint a hydrant in the Historic Downtown Wilson Municipal Service District (MSD), submit the completed application (front & back) along with payment and a color sketch on the provided template.

APPLICATION DUE BY: Monday, May 8th, 2017

EVENT: Saturday, May 20th at 10 am. Rain Date, June 3rd.

Contact Information

Business or Group	
Contact Name	
Street Address	
City ST ZIP Code	
Phone	
Email Address	

Preferred Hydrant Location - Identify by hydrant number on map

1st _____ 2nd _____ 3rd _____

Attach sketch (in color) on provided template. If you would like to sponsor a hydrant but need assistance in designing or painting, you may partner with an artist, school or group to develop and execute the design. You are responsible for contacting and selecting your art partner but we can assist with suggestions and resources. If your submitted design is not initially approved, changes may be made to meet the guidelines or you may receive a refund.

COMPLETED application, sketch & payment due IN-HOUSE By Monday, May 8th 2017.

Please make checks payable to WDDC.

Reference business/group name on check to ensure payment is credited correctly.

Mail to: Wilson Downtown Development Corporation
PO BOX 10
Wilson NC 27894
Attn: Susan Kellum

OR Deliver to front desk of City Hall
112 Goldsboro Street, Wilson
Attn: Susan Kellum 27894
Open Monday–Friday, 8am-5pm

PROVIDE COLOR SKETCH OF PROPOSED ARTWORK
ON HYDRANT TEMPLATE BELOW

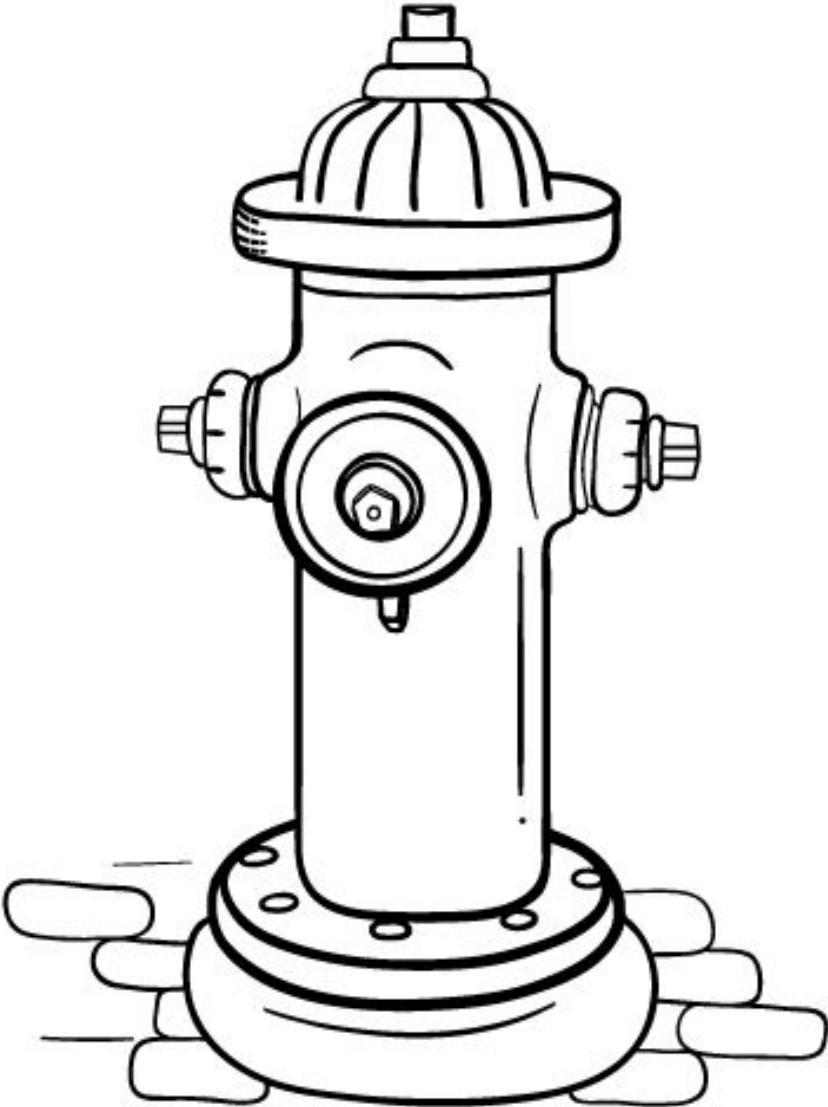

Business or Group: _____

Contact Name: _____

Phone: _____ Email: _____